

**thermaline S90 BAIN MARIE, ELEKTRISCH
BAIN MARIE, ELECTRIC
BAGNOMARIA, ELETTRICHE
BAIN-MARIE, ÉLECTRIQUE**

MODEL CODE / PNC
freistehend, free standing , isolato, isolé einseitig bedienbar, operated from one side, comando da un lato, utilisable d'un côté
ABARAOOOO / 582290 ABARHAOOO / 582291 ABARBAOOO / 599610 ABATAAOOO / 582300 ABATHAOOO / 582301 ABATBAOOO / 582306
freistehend, free standing , isolato, isolé beidseitig bedienbar, operated from both sides, comando da due lati, utilisable des deux côtés
ABARACOOO / 582294 ABARHCOOO / 582295 ABARBCOOO / 582298 ABATACOOO / 582304 ABATHCOOO / 582305 ABATBCOOO / 582310
an Wand, against wall, contro la parete, contre cloison,
ABARAFOOO / 582292 ABARHFOOO / 582293 ABARBFOOO / 599609 ABATAFOOO / 582302 ABATHFOOO / 582303 ABATBFOOO / 582308 ABAROI000 / 582517 ABATOIOOO / 582518

**DE ERSATZTEILLISTE
GB SPARE PARTS LIST
IT LISTA DEI PEZZI DI RICAMBIO
FR LISTE DES PIÈCES DE RECHANGE**

doc.	62.9587.02
edition	2
dat.	01.2004

**thermaline S90 WÄRMESCHRANK, ELEKTRISCH
HOT CUPBOARD, ELECTRIC
ARMADIO RISCALDANTE, ELETTRICHE
ARMOIRE CHAUFFANTE, ÉLECTRIQUE**

MODEL CODE / PNC
freistehend, free standing , isolato, isolé einseitig bedienbar, operated from one side, comando da un lato, utilisable d'un côté
ABARBAOOOO / 599610 ABATBAOOOO / 582306

freistehend, free standing , isolato, isolé beidseitig bedienbar, operated from both sides, comando da due lati, utilisable des deux côtés
ABARBCOOOO / 582298 ABATBCOOOO / 582310

an Wand, against wall, contro la parete, contre cloison,
ABARBFOOOO / 599609 ABATBFOOOO / 582308

Series No.: starting from 401...

DE	ERSATZTEILLISTE
GB	SPARE PARTS LIST
IT	LISTA DEI PEZZI DI RICAMBIO
FR	LISTE DES PIÈCES DE RECHANGE

doc.	62.9651.02
edition	2
dat.	01.2004

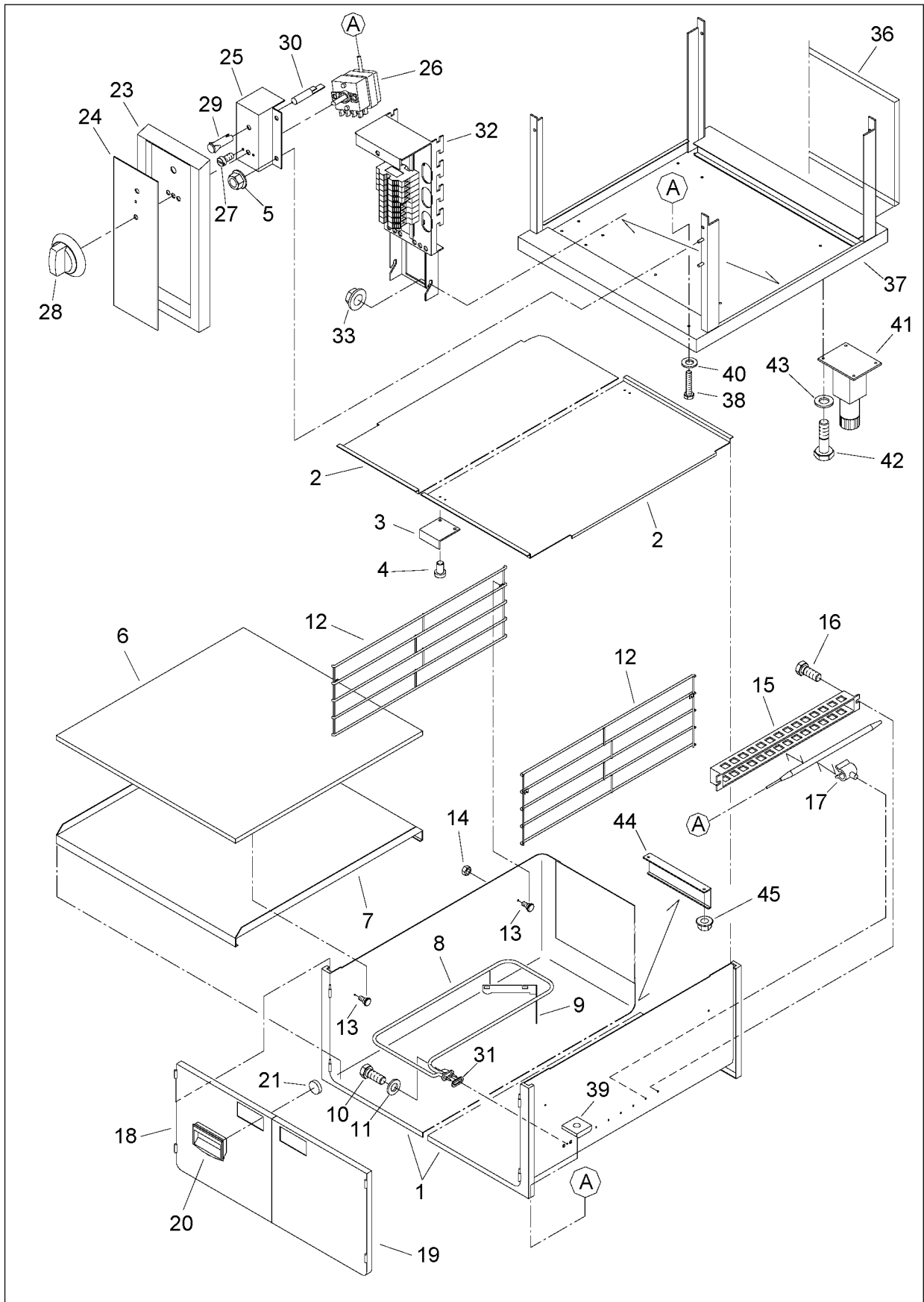

62.9651.02-1(2)		DE	GB	IT	FR	B			E			W			
		Bezeichnung	designation	designazione	désignation	1000	700	500	1000	700	500	1000	700	500	intr
Pos.	Product No.	Wärmeschrank	hot cupboard	armadio riscaldante	armoire chauffante										
		Einbauteile	installation parts	pezzi d'installazione	pièces d'installation										
1	62.4818.25	Wärmeschrank kompl.	hot cupboard compl.	armadio riscaldante compl.	armoire chauffante compl.	1									
	62.4084.03	Wärmeschrank kompl.	hot cupboard compl.	armadio riscaldante compl.	armoire chauffante compl.		1								
	62.4818.22	Wärmeschrank kompl.	hot cupboard compl.	armadio riscaldante compl.	armoire chauffante compl.			1							
	62.4817.05	Wärmeschrank kompl.	hot cupboard compl.	armadio riscaldante compl.	armoire chauffante compl.				1			1			
	62.4080.03	Wärmeschrank kompl.	hot cupboard compl.	armadio riscaldante compl.	armoire chauffante compl.					1			1		
	62.4817.02	Wärmeschrank kompl.	hot cupboard compl.	armadio riscaldante compl.	armoire chauffante compl.						1			1	
2	62.4766.08	Deckel	lid	coperchio	couvercle	1									
	62.4766.05	Deckel	lid	coperchio	couvercle		1								
	62.4766.02	Deckel	lid	coperchio	couvercle			1							
	62.4763.08	Deckel	lid	coperchio	couvercle				1			1			
	62.4763.05	Deckel	lid	coperchio	couvercle					1			1		
	62.4763.02	Deckel	lid	coperchio	couvercle						1			1	
3	72.6121	Winkel	angle	angolo	angle	2	2		1	1		1	1		
	72.6183	Winkel	angle	angolo	angle			2			1			1	
4	1 701 1547	Niete	rivet	rivetta	rivet	4	4	4	2	2	2	2	2	2	
5	712 044 120.05	Mutter M5	nut M5	dado M5	écrou M5	2	2	2	2	2	2	2	2	2	
6	72.6321.08	Tablar	shelf	mensola	rayonnage	1									
	72.6321.05	Tablar	shelf	mensola	rayonnage		1								
	72.6321.02	Tablar	shelf	mensola	rayonnage			1							
	72.6321.09	Tablar	shelf	mensola	rayonnage				1			1			
	72.6321.06	Tablar	shelf	mensola	rayonnage					1			1		
	72.6321.03	Tablar	shelf	mensola	rayonnage						1			1	
7	72.6248	Tablar	shelf	mensola	rayonnage	1									
	62.8509	Tablar	shelf	mensola	rayonnage	1									42. week 2005
	72.6255	Tablar	shelf	mensola	rayonnage		1								
	62.8508	Tablar	shelf	mensola	rayonnage		1								42. week 2005
	72.6249	Tablar	shelf	mensola	rayonnage			1							

62.9651.02-1(2)		DE	GB	IT	FR	B			E			W			
		Bezeichnung	designation	designazione	désignation	1000	700	500	1000	700	500	1000	700	500	intr
Pos.	Product No.	Wärmeschrank	hot cupboard	armadio riscaldante	armoire chauffante										
		Einbauteile	installation parts	pezzi d'installazione	pièces d'installation										
	62.8507	Tablar	shelf	mensola	rayonnage			1							42. week 2005
	72.6252	Tablar	shelf	mensola	rayonnage				1			1			
	72.6256	Tablar	shelf	mensola	rayonnage					1			1		
	72.6253	Tablar	shelf	mensola	rayonnage						1			1	
8	62.4058.03	Heizung 400 V	heating 400 V	riscaldamento 400 V	chauffage 400 V	1			1			1			
	62.4082.03	Heizung 400 V	heating 400 V	riscaldamento 400 V	chauffage 400 V		1			1			1		
	62.3937.03	Heizung 400 V	heating 400 V	riscaldamento 400 V	chauffage 400 V			1			1			1	
9	72.6257	Halter	support	sostegno	fixation	2		1	2		1	2		1	
	62.4208	Halter	support	sostegno	fixation		2			2			2		
10	10 3179	Schraube M5x12	screw M5x12	per armadio M5x12	pour armoire M5x12	1	1	1	1	1	1	1	1	1	
11	1 701 7002	Scheibe M5	washer M5	disco M5	rondelle M5	1	1	1	1	1	1	1	1	1	
12	72.6087.01	Tablarhalter	shelf fixation	fissaggio di mensola	fixation pour rayonnage				2	2	2	2	2	2	
	72.6087.02	Tablarhalter	shelf fixation	fissaggio di mensola	fixation pour rayonnage	2	2	2							
13	72.6088	Bolzen	bolt	bullone	goujons	4	4	4	4	4	4	4	4	4	
14	1 701 3004	Mutter	nut	dado	écrou	4	4	4	4	4	4	4	4	4	
15	72.6251	Schutzblech	protection sheet	lamiera di protezione	tôle de protection	1	1	1	1	1	1	1	1	1	
16	1 701 1041	Schraube M4x6	screw M4x6	per armadio M4x6	pour armoire M4x6	2	2	2	2	2	2	2	2	2	
17	1 201 2020	Fühlerbefestigung	sensor support	sostegno del sensore	support de sonde	2	2	2	2	2	2	2	2	2	
18	62.3563	Flügeltüre L	wing door l	porta a battenti s	porte à battant g	2			1			1			
	62.4075	Flügeltüre L	wing door l	porta a battenti s	porte à battant g		2			1			1		
	62.3604	Flügeltüre L	wing door l	porta a battenti s	porte à battant g			1			1			1	
19	62.3564	Flügeltüre R	wing door r	porta a battenti d	porte à battant d	2			1			1			
	62.4073	Flügeltüre R	wing door r	porta a battenti d	porte à battant d		2			1			1		
	62.3605	Flügeltüre R	wing door r	porta a battenti d	porte à battant d			1							
20	62.3575	Griff	knob	manetta	poignée	4	4	2	2	2	1	2	2	1	
21	62.6119	Magnet	magnet	magnete	aimant	4	4	2	2	2	1	2	2	1	
22	1 701 2604	Schraube M6x50	screw M6x50	per armadio M6x50	pour armoire M6x50	2	2	2	2	2	2	2	2	2	
23	62.4847.02	Blende	filler	copertura	bandeau	1			1			1			
	62.4847.01	Blende	filler	copertura	bandeau		1	1		1	1		1	1	
24	62.3641	Folie	foil	lamina	pellicule	1			1			1			
	62.3639	Folie	foil	lamina	pellicule		1	1		1	1		1	1	

62.9651.02-1(2)		DE	GB	IT	FR	B			E			W			
		Bezeichnung	designation	designazione	désignation	1000	700	500	1000	700	500	1000	700	500	intr
Pos.	Product No.	Wärmeschrank	hot cupboard	armadio riscaldante	armoire chauffante										
		Einbauteile	installation parts	pezzi d'installazione	pièces d'installation										
25	62.3849	Befestigungsblech	mounting plate	lamiera	tôle de fixation	1			1			1			
	62.5095	Befestigungsblech	mounting plate	lamiera	tôle de fixation		1	1		1	1		1	1	
26	712 344 039	Regler	regulator	regolatore	régulateur	1	1	1	1	1	1	1	1	1	
27	1 701 1006	Schraube M4x8	screw M4x8	per armadio M4x8	pour armoire M4x8	2	2	2	2	2	2	2	2	2	
28	62.3568	Griff	knob	manetta	poignée	1	1	1	1	1	1	1	1	1	
29	72.5938.08	Fassung	socket	disposizione	monture	1	1	1	1	1	1	1	1	1	
30	72.5938.04	Glimmlampe grün	glowing lamp green	lampada verde	lampe fluorescente vert	1	1	1	1	1	1	1	1	1	
31	72.1120	Dichtung	sealing	guarnizione	joint	1	1	1	1	1	1	1	1	1	
32	62.4898.14	Klemme	terminal	morsa	borne	1	1	1	1	1	1	1	1	1	
33	712 044 120.06	Mutter M6	nut M6	dado M6	écrou M6	2	2	2	2	2	2	2	2	2	
36	62.5068.01	Blende 100	filler 100	copertura 100	bandeau 100			1							
	62.5068.18	Blende 170	filler 170	copertura 170	bandeau 170	1									
	62.5068.05	Blende 500	filler 500	copertura 500	bandeau 500						1				
	62.5068.10	Blende 1000	filler 1000	copertura 1000	bandeau 1000				1						
37	62.4774.10	Gestell	frame	telaio	cadre	1			1			1			
	62.4774.07	Gestell	frame	telaio	cadre		1			1			1		
	62.4774.05	Gestell	frame	telaio	cadre			1			1			1	
38	1 701 2569	Schraube M6x16	screw M6x16	vite M6x16	vis M6x16	6	6	6	6	6	6	6	6	6	
39	1 106 1187	Mutter M6	nut M6	dado M6	écrou M6	6	6	6	6	6	6	6	6	6	
40	1 701 5051	Fächerscheibe M6	serrated lock washer	rondella serrante M6	rondelle de serrage	6	6	6	6	6	6	6	6	6	
41	1 701 2761	Fuss	foot	piede	pied	4	4	4	4	4	4	4	4	4	
42	1 701 2582	Schraube M8x16	screw M8x16	vite M8x16	vis M8x16	16	16	16	16	16	16	16	16	16	
43	1 701 5049	Fächerscheibe M8	serrated lock washer M8	rondella serrante M8	rondelle de serrage M8	16	16	16	16	16	16	16	16	16	
B		beidseitig bedienbar	operated from both sides	comando da due lati	utilisable des deux côtés										
E		einseitig bedienbar	operated from one side	comando da un lato	utilisable d'un côté										
W		an Wand stehend	against wall	contro la parete	contre cloison										